



*High Performance DLP Home Cinema Projector*



*Action! model three*

The projectiondesign Action! model three is the world's most powerful single chip DLP™ home theatre projector. It has higher true contrast than any other projector or technology, without using sequential contrast adjustment that varies the actual output of the projector. Thanks in full to our proprietary optics, it is possible to have both bright and dark scenes at the same time, unlike any competing projector.



*High Definition DLP™ technology*

The HD2+ DC3™ DMD™ with 1280 x 720 pixel resolution is ideal for High Definition TV and video, and provides images with outstanding detail and clarity. The HD2+ DC3™ DMD™ is the latest generation DLP™ technology from Texas Instruments, optimized for video display in home theatres and smaller cinemas, achieving dramatically increased image quality over the previous generation.



*High end video processing*

The Action! model three features the highly regarded Faroudja® FLI2310 deinterlacing chipset for high end, high performance video processing. It is compatible with both standard definition and high definition analogue input sources. Patented technologies such as 3:2 and 2:2 pulldown with bad edit detection, DCDi™ (Directional Correlational Deinterlacing™), cross colour suppression and TrueLife™ non-linear enhancement combine to create superb results. Standard interlaced video is converted to high resolution progressive scan images - free from artefacts, and with sharp, detailed pictures with deeply saturated colours.

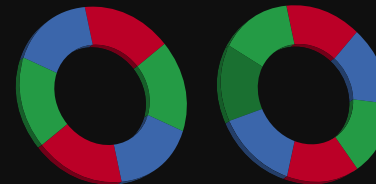

*6- and 7-segment colour wheel options.*

Unlike any other manufacturer, we offer the model three home theatre projector with different colour wheel options. Both a 6-segment 5x, and 7-segment 5x version version is available. While the 6-segment colour wheel provides a little more punch and brightness, as well as superbly smooth image panning, the 7-segment wheel greatly stabilises and improves definition in low level information, improving visibility of low level minute detail.

*High precision glass lenses*

A range of six lenses is available, to cover any installation need. From ultra wide angle at 0.88 : 1, designed for rear projection, to the super tele zoom at 4.4 - 7.7 : 1 ratio. All lenses are glass-only, manufactured to the highest possible standards, with very high precision CNC-machined mechanical interfaces.



*Optical lens shift for undistorted imaging*

All lenses feature full lens shift both horizontally and vertically, allowing complete flexibility in installation, without altering or distorting the image.

*Infinitely adjustable output brightness*

In order to match the Action! model three to any desired on-screen brightness, the user can adjust power output for each lamp individually, in addition to adjusting illumination



*HDTV resolution.*

*DLP™ technology.*

*Unmatched dynamics.*

*Faroudja® video processing.*

*Award winning design.*

*projectiondesign home cinema projectors are the result of passion and enthusiasm. Built to please not only ourselves, but also discerning film and video enthusiasts, the Action! series of projectors is the natural choice for those looking for realistic, dynamic home cinema projection.*

apertures with extremely high precision. This gives an infinitely adjustable brightness output from about 500 lumens, to as high as 2500 ANSI lumens, enough for even the largest screens.

*Complete control and command*

The Action! model three features an extremely comprehensive RS232 and TCP/IP interfaces, and can easily be integrated with any type of dedicated system controller, for instance AMX or Crestron. For simpler setups, the backlit IR remote control also features a wired connection and programmable ID settings, so it can be used in any environment.

*Upgradable input connectivity*

With HDCP-compatible DVI, high-bandwidth component and RGBHV on separate BNC binding posts, the Action! model three is dedicated to high resolution signal processing in every possible way. Through our proprietary XPort™ technology, the owner is also ensured perfect future upgradability, as we can add on any type of interface required.

*True optical contrast vs sequential contrast*

True optical contrast will always have full white level and full black level available with any picture content. A torch pointing at the camera in a dark cave will have true, intense white light, at the same time as the dark areas will be black. Sequential contrast, on the other hand, will control the output of the projector based on image content. Only with bright content pictures will the projector have intensive brightness. The dark cave may be dark, but the torch will look like a candle, as it will not have an intensive output. With mixed exposure scenes, a projector with dynamic iris and contrast will have neither bright, nor dark images, whereas true optical contrast will have maximum available contrast at all times, providing a much more dynamic image.

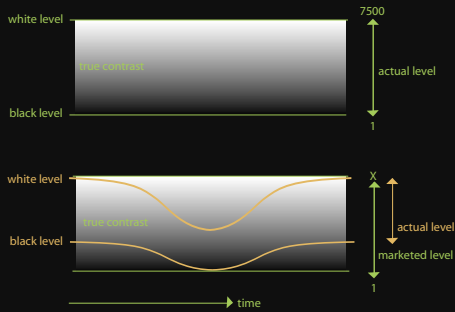

Top: Intensive white and deep black in the same picture with true optical contrast - deep black, but reduced whites with dynamic contrast.

Bottom: Deep black and intensive highs with true optical contrast - flat and compressed dynamics with dynamic contrast.

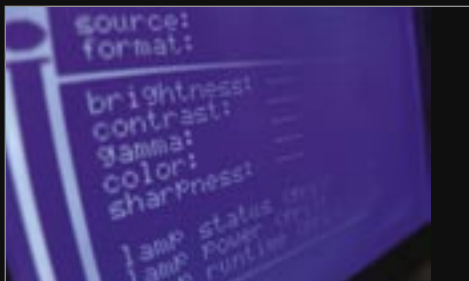

**technical specifications**

display concept	single chip HD2+ DC3™ DLP™ technology, 1280 x 720 resolution (16:9 wide screen)  DuArch™ illumination architecture (pat. pending) dual 6/7-segment, 5-speed RGBRGB/G (NDG) colour wheels
brightness	continuously adjustable 500 - 2500 ANSI lumens
true optical contrast	7500 : 1 (at small aperture setting)
lens aperture control	fully continuous aperture control for all lenses
input signal compatibility	1080i/p, 720p, 576i / 576p, 480i / 480p, PAL SECAM, NTSC digital and analog RGB upgradeable
projection lenses	0.88 : 1 fixed focal wide angle (on axis only) 1.30 : 1 fixed focal wide angle (fully shiftable) 1.42 - 1.85 : 1 wide angle zoom lens (fully shiftable) 1.85 - 2.75 : 1 standard zoom lens (fully shiftable) 2.75 - 4.40 : 1 short tele zoom lens (fully shiftable) 4.40 - 7.70 : 1 long tele zoom lens (fully shiftable) all lenses with fully motorized operation
optical lens shift	vertical: +/- 110% horizontal: +/- 90%
lamp	250W UHP™ x 2, continuously variable power
lamp life	8000 hrs (max) typical in low power setting (2000 hours min typ)
video processing	DCDi™ by Faroudja® (FLI 2310) 10-bit AD converters single UniBoard™ video processing
connectivity	DVI-D (HDCP) (DVI or HDMI digital RGB) 3x RCA (YPbPr, YCbCr) (component video) 1x S-Video (s-video) 1x RCA (composite video) HDD-15 (RGBHV, RGBS, RGSB, YUV, YPbPr, YCbCr) BNC x5 (RGBHV, RGBS, RGSB, YPbPr, YCbCr) XPort™ - upgradeable interface
control	TCP/IP RS232 IR remote control, with IR repeater input USB
operating noise level	30 dB(A) typical in-room
dimensions (w x d x h)	510 x 376 x 223 mm / 20.0" x 14.8" x 8.8"
weight	12.6 kg / 27.8 lbs plus lens

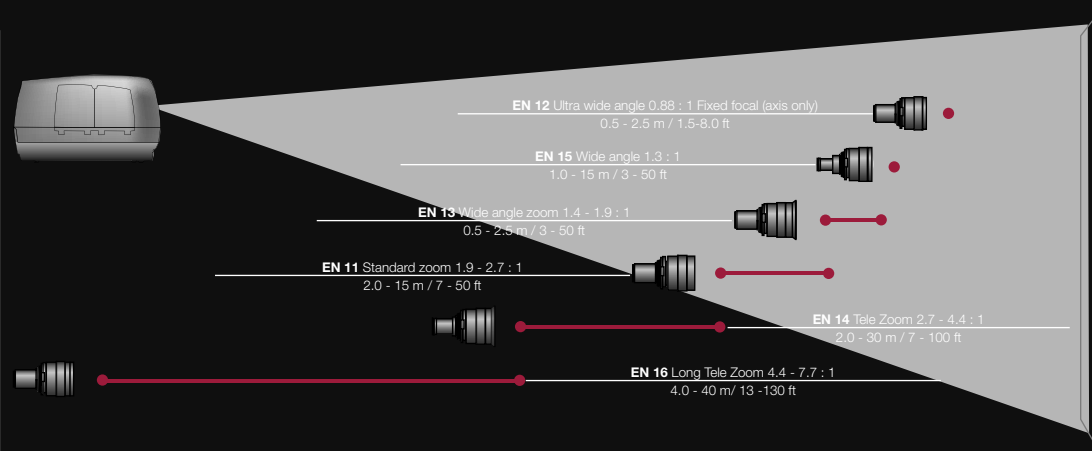

projectiondesign as  
habornveien 53  
N-1630 gamle fredrikstad  
norway



**HIGH PERFORMANCE PROJECTORS™**